

2301A Speed Controls

APPLICATIONS

The 2301A Speed Control controls the speed or load of diesel or gas engines, or steam or gas turbines.

The unit provides control in the isochronous mode, with droop available through an externally wired potentiometer. The isochronous mode is used for constant speed of the controlled prime mover as long as it is able to provide power to satisfy the load

The 2301A Speed Control is compatible with Woodward SPM-A synchronizers, load sensors, and other power generation controls. These controls can be added to the system at any time, using the auxiliary or SPM inputs to the 2301A Speed Control.

The 2301A Speed Control is available for forward-or reverse-acting applications, and can be used with single or tandem actuators. High voltage models accept 88 to 132 Vac or 90 to 150 Vac, and low voltage models accept 10 to 40 Vdc supply for control power.

2301A Speed Controls are also available with 4-20 mA speed-setting input (see Product specification 02301).

Two Set Speeds

The control has potentiometer-set Low Idle and Rated Speed settings which are selected with a switch.

DESCRIPTION

The 2301A Speed Control is housed in a sheet-metal chassis and consists of a single printed circuit board. All potentiometers are accessible from the front of the chassis.

Speed range is set by an internal dip switch inside the aluminum cover of the control. Speeds are based on the frequency of a sensed gear, not necessarily engine rpm.

Speed Trim

A speed trim potentiometer or digital reference unit may be connected to the control to adjust prime-mover speed from a remote location.

Minimum Fuel

A switch may be wired to the control to call for minimum fuel to the prime mover. This contact is used for normal shutdown.

Failed Signal Circuit

The 2301A Speed Control constantly monitors the signal from the magnetic pickup. Should the signal be below a minimum threshold, the control sends a minimum-fuel signal to the actuator. This circuit may be overridden while starting slow-cranking engines.

- Low- and High-Voltage Models
- Idle and Rated Speed Settings
- Idle to Rated Speed Linear Ramp
- Automatic Start-Fuel Limiting
- Failed Speed Sensor Detector
- EU Directive Compliant



SPECIAL FEATURES

Start Fuel Limit

A special circuit in the control provides a limit to the maximum fuel setting while an engine is starting. This feature helps limit exhaust smoke and engine damage.

Ramp Times

Acceleration time from low idle to rated speed may be adjusted from 1 to 22 seconds. The ramp time from rated to idle is always less than 1 second, regardless of the setting of the ramp-time potentiometer.

Reset, Gain, Actuator Compensation

Three adjustments are available to permit accurate, responsive engine control. The GAIN control adjusts response time to transient load changes. RESET adjusts the overshoot and undershoot which occurs in response to load swings. ACTUATOR COMPENSATION sets dynamic response time within a 0 to 500 millisecond range to match the time constant of the fuel system.

Power Supply

2301A Speed Controls accept either a high- or a low-voltage power source. The low-voltage model operates on 10 to 40 Vdc and the high-voltage model operates on either 88 to 130 Vac or 90 to 150 Vdc.

SPECIFICATIONS

Speed Range

A switch selects one of the following ranges (rating is based on frequency of sensed gear, not engine rpm).

500 to 1500 Hz	2000 to 6000 Hz
1000 to 3000 Hz	4000 to 12000 Hz

Speed Sensing

1 to 30 Vac. Maximum load is 1 Kilohm at 1 Khz.

External Speed Trim

+/- 5 percent speed adjustment with 100 ohm potentiometer.

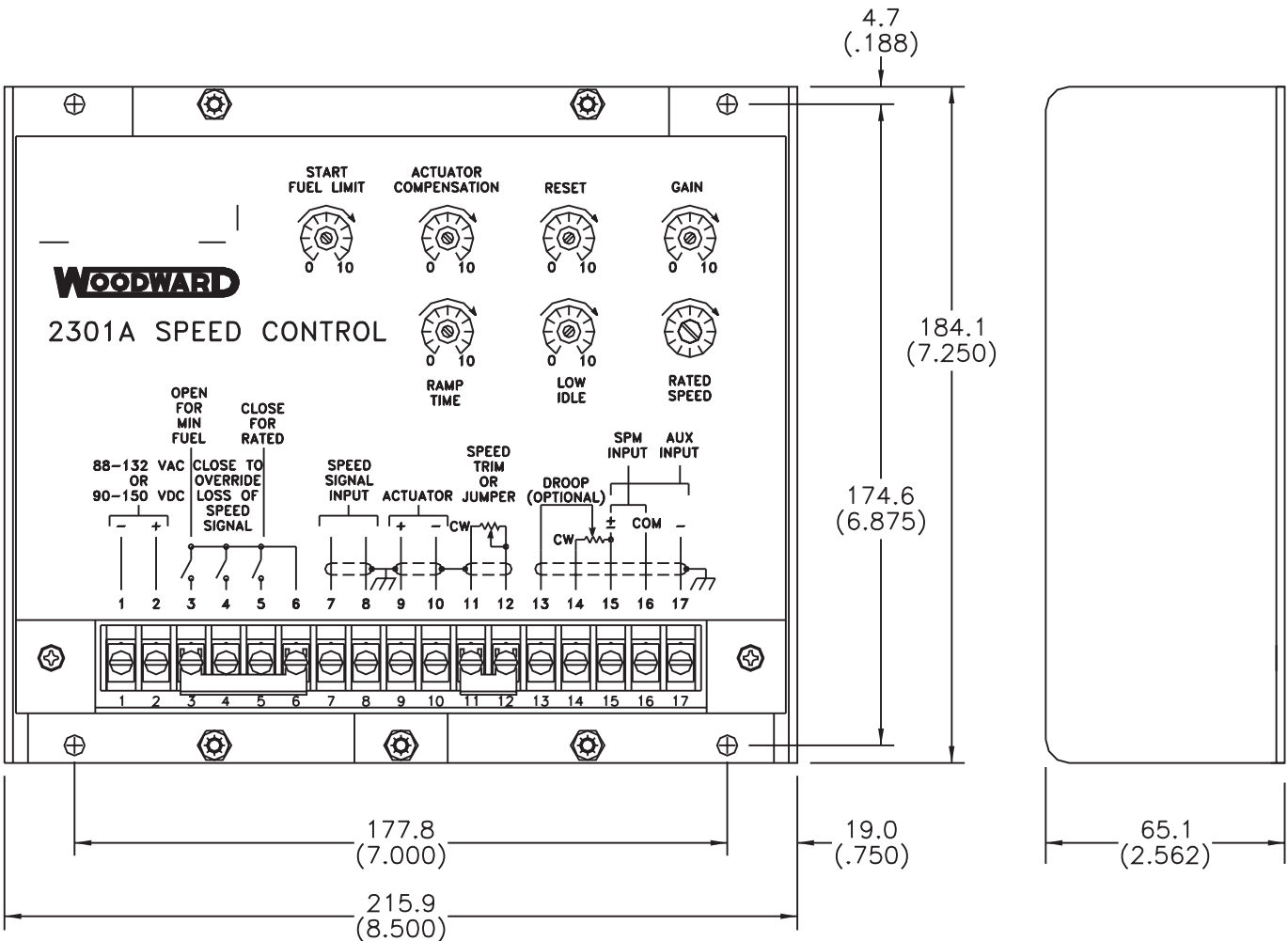

NOTE: INCHES SHOWN IN PARENTHESES

820-025
89-7-21 GA

OUTLINE DRAWING OF 2301A SPEED CONTROL

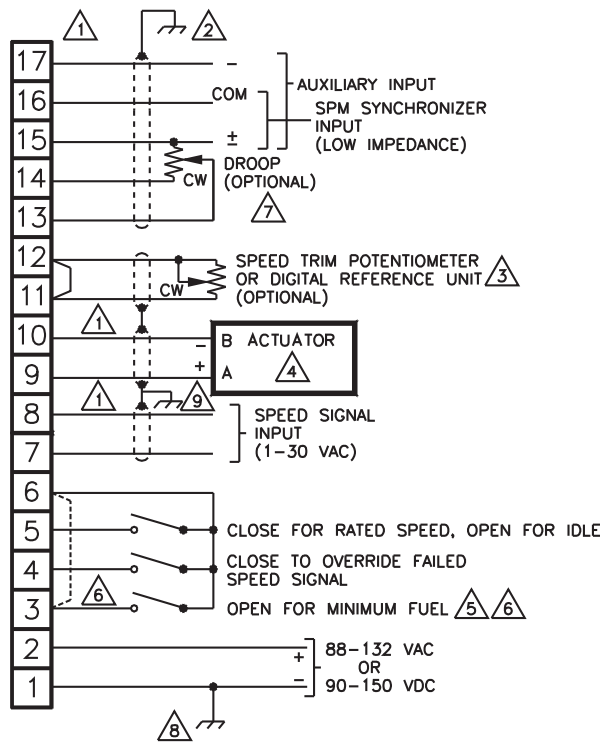

High Voltage Plant Wiring Diagram

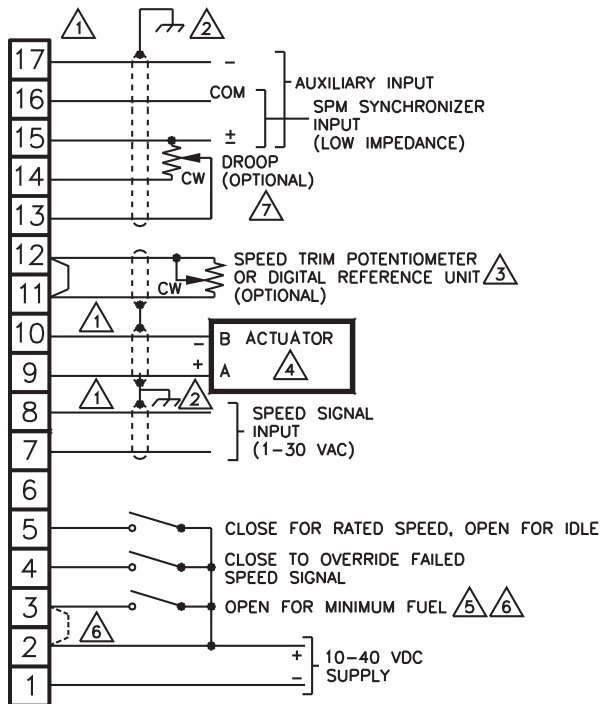

DETAIL "A"
CONNECTION FOR SERIES OR TANDEM OPERATION

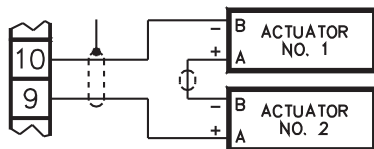

NOTES:

- 1 SHIELDED WIRES TO BE TWISTED PAIRS OR TRIPLETS WITH SHIELD GROUNDED AT CONTROL END ONLY.
- 2 GROUND SHIELDS AT GROUNDING LUG ON THE CHASSIS PLATE BELOW TERMINAL 9. KEEP GROUNDING CONNECTIONS UNDER 2 INCHES (5 CENTIMETERS) LENGTH.
- 3 REMOVE JUMPER BETWEEN TERMINALS 11 & 12 IF SPEED TRIM POTENTIOMETER OR DIGITAL REFERENCE UNIT IS USED. IF SPEED TRIM POTENTIOMETER IS USED, A HIGH QUALITY 100 OHM, 10 TURN POTENTIOMETER SIMILAR TO WOODWARD P/N 1657-537 IS RECOMMENDED. 100 OHMS WILL GIVE APPROXIMATELY ±5% SPEED ADJUSTMENT.
- 4 FOR SERIES OR TANDEM OPERATION, SEE DETAIL "A".
- 5 **WARNING:** DO NOT USE FOR EMERGENCY SHUTDOWN. THE PRIME MOVER SHOULD BE EQUIPPED WITH A SEPARATE OVERSPEED, OVERTEMPERATURE OR OVERPRESSURE SHUTDOWN DEVICE(S), TO PROTECT AGAINST RUNAWAY OR DAMAGE TO THE PRIME MOVER WITH POSSIBLE PERSONAL INJURY OR LOSS OF LIFE.
- 6 REMOVE JUMPER IF MINIMUM FUEL SWITCH IS USED.
- 7 USE A 2K POTENTIOMETER FOR UP TO 7.5% DROOP WHEN USING 2/3 ACTUATOR TRAVEL FOR 0 TO 100% LOAD. MAKE NO CONNECTION TO TERMINALS 13 AND 14 IF DROOP IS NOT REQUIRED.
- 8 GROUND AS REQUIRED BY LOCAL WIRING CODE.
- 9 A SOLID GROUND CONNECTION MUST BE MADE FROM "EARTH" OR "GROUND" TO THE GROUNDING LUG ON THE CHASSIS PLATE BELOW TERMINAL 9 TO PROVIDE PROPER CHASSIS GROUNDING. REFER TO LOCAL WIRING CODES FOR PROPER GROUNDING METHODS.

Low Voltage Plant Wiring Diagram

2301A SPEED CONTROL PLANT WIRING DIAGRAM



3800 N. Wilson Ave.
 P.O. Box 3800
 Loveland, CO, U.S.A.
 80539-3800
 Ph: 1 970-663-3900
 Ph: 1 800-835-5182
 Fax: 1 970-962-7050
 www.woodward.com



**International
 Woodward Offices:**

- Australia
- Brazil
- China
- Czech Republic
- Germany
- India
- Japan: *Chiba & Kobe*
- Korea
- Mexico
- New Zealand
- Poland
- Singapore
- The Netherlands
- U. A. E.
- U.K.
- U.S.A.:
 - Alabama
 - California
 - Illinois
 - Pennsylvania
 - Texas
 - Washington

CORPORATE
 HEADQUARTERS/
 AIRCRAFT CONTROLS
 Rockford, IL, U.S.A.
 1 815-877-7441

This document is distributed for informational purposes only. It is not to be construed as creating or becoming part of any Woodward Governor Company contractual or warranty obligation unless expressly stated in a written sales contract.

© Woodward Governor
 Company, 1989
 All Rights Reserved

Signal to Actuator

0 to 200 mA, 30 to 45 ohms, standard

Temperature Limits

-40 to 85 °C (-40 to 185 °F) operating temperature

-55 to 105 °C (-67 to 221 °F) storage temperature

Humidity Limits

95 percent at 38 °C (100 °F)

Vibration and Shock

4 Gs vibration between 5 to 500 Hz. 60 Gs shock

Steady State Speed Band

+/- 1/4 of 1 percent of rated speed

Auxiliary input allows load sharing accuracy of +/- 5 percent of rated load with speed settings matched when using optional load sensing equipment.

DECLARATION OF INCORPORATION

In accordance with the EMC Directive 89/336/EEC and its amendments, this controlling device, manufactured by the Woodward Governor Company, is applied solely as a component to be incorporated into an engine prime mover system. Woodward Governor declares that this controlling device complies with the requirements of EN50081-2 and EN50082-2 when put into service per the installation and operating instructions outlined in the product manual.

NOTICE: This controlling device is intended to be put into service only upon incorporation into an engine prime mover system that itself has met the requirements of the above Directive and bears the CE mark.

For more information contact: